

5/16" HEX

WELDED CONSTRUCTION

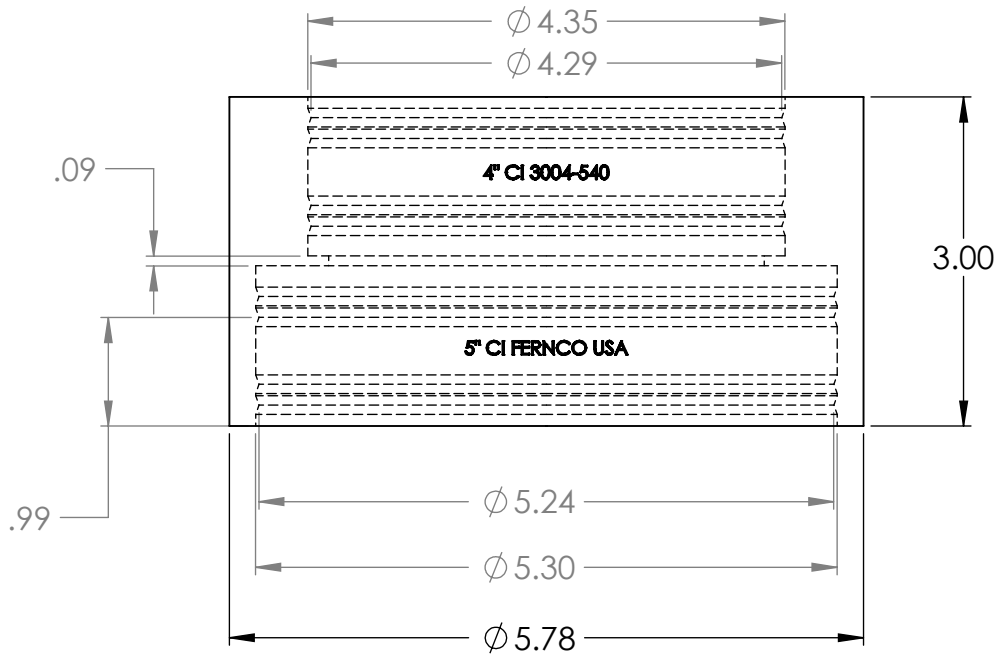

LEGEND:
 CI = NO-HUB CAST IRON
 PL = SCH. 40 PVC
 ST = STEEL, IRON PIPE SIZE
 XHCI = EXTRA HEAVY WEIGHT CAST IRON

The Information Contained in this Drawing is the Sole Property of Fernco. Any Reproduction in Part or in Whole without Written Permission is Prohibited.

Clamp/Shield: All 300 SS, Installation Torque 60 in-lb
 Gasket Material: Rubber Complying to ASTM C564
 Coupling: Complies to ASTM C 1460
 Temperature Range: -30 °F to 180 °F
 Drain, waste and Vent Use Only



FERNCO INC. DAVISON MI.

Tolerance:
 Angular ± 3°
 X = ± 0.09
 .XX = ± 0.06

SHEET 1 OF 1
 Dimensions are in Inches

Drawn by: SR

DATE: 3/26/2015

Description:

Part Number:

3004-540

5" CI to 4" CI

Do Not Scale